



**GSR-E** SERIES

## INTRODUCTION

The GSR series regulators are dual-stage devices designed for residential and small industrial use. These regulators can be used within a service box or mounted directly on the installation with special connection options.

GSR series regulators are compatible with various non-corrosive gases, including natural gas, city gas, air, propane, LPG, and other similar gases.

Thanks to their compact design, GSR regulators save space and offer the advantages of easy installation and setup, high regulation precision, and safety. These regulators are manufactured in compliance with TS 10624 and TS EN 88-2 standards.

Inlet Pressure	0,5 - 6 bar
Outlet Pressure	15 - 350 mbar
AC / RG	5 / 10
Ambient Temperature	-20°C to +60°C
Capacity Range - @21 mbar	6/10/25 m <sup>3</sup> /h
Capacity Range - @300 mbar	30 m <sup>3</sup> /h

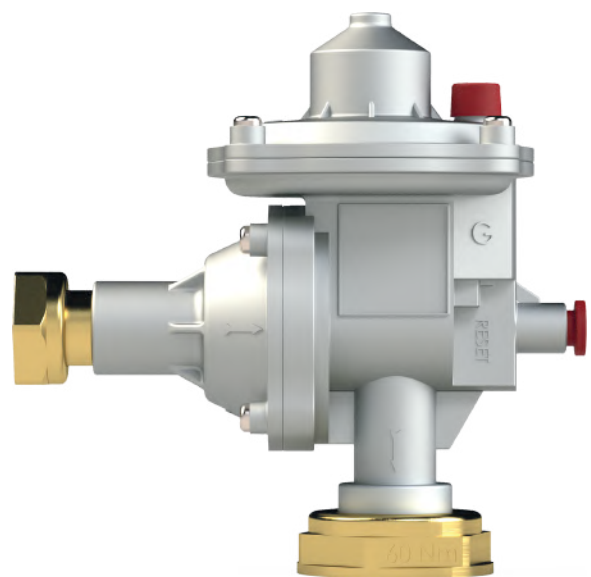

## DIMENSION AND WEIGHTS

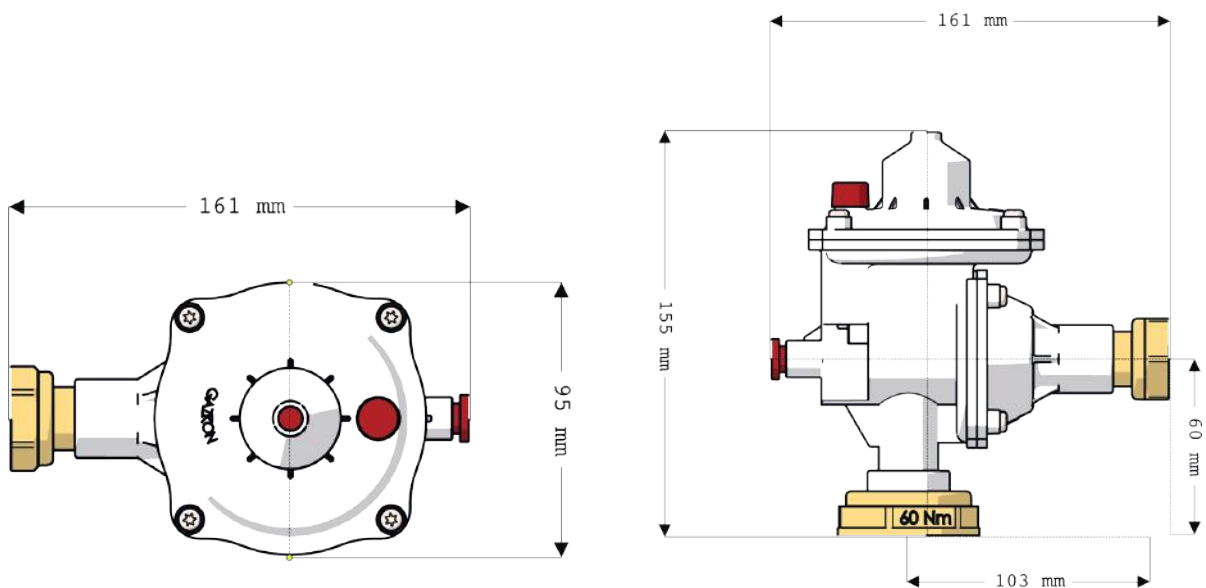

## OPERATING PRINCIPLE

The gas from the pipeline directly enters the inlet connection and is initially cleaned by passing through a filter. The gas that passes through the filter reaches the first stage of the regulator, where its pressure is reduced to the range of 0.3-0.8 bar. The first stage of the regulator consists of a diaphragm, a spring, and an orifice. As the gas passes through the orifice and seal, its pressure is reduced to the desired level, and it enters the first-stage chamber. The gas pressure has been preset and depends on the stiffness of the spring, typically falling within the range of 0.2 to 0.3 bar (for a 21 mbar outlet pressure). The second stage of the regulator consists of a diaphragm, a spring, and an orifice. The gas from the first stage, as it passes through the orifice and seal, has its pressure further reduced to the pre-set outlet pressure, reaching the second-stage section. From here, it is made available for use through the outlet connection. The outlet pressure is factory-set and sealed but can be adjusted at the point of use if needed. The second-stage regulation is limited by an excess flow valve. This ensures that the regulator's capacity is limited. Typically, the regulator is set to shut off the flow when it exceeds 10% of its nominal capacity. An increase in pressure on the outlet side triggers the relief safety function, releasing excess pressure into the atmosphere.

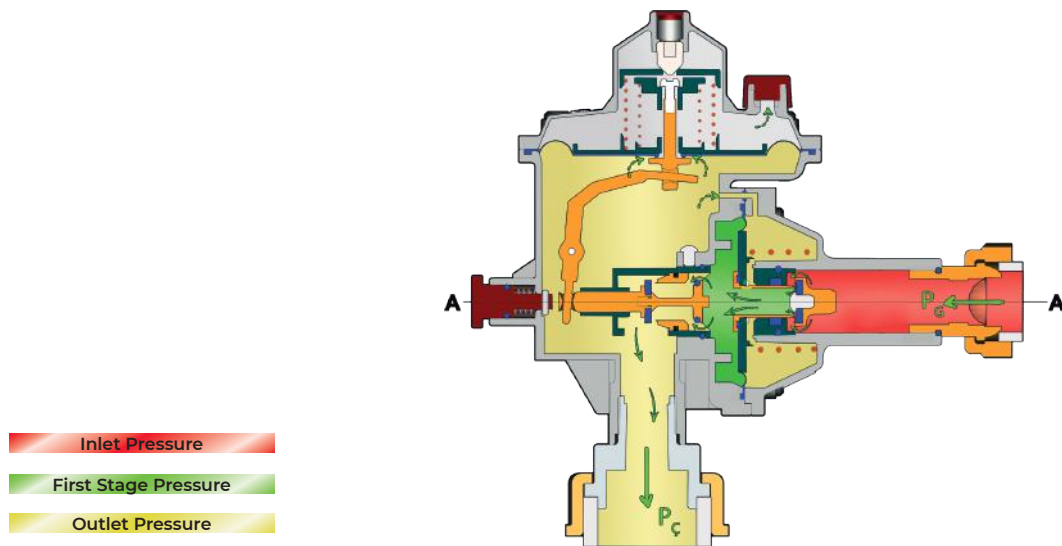

## MATERIALS

BODY AND HEADS Die-Cast Aluminum

INTERNAL PARTS Brass/Plastic

DIAPHRAGM NITRILE Nitrile Rubber

## COMMISSIONING

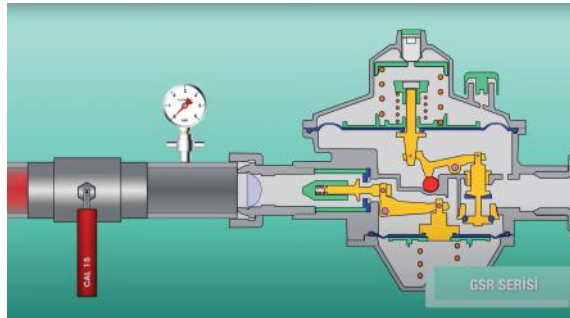

Before commissioning the regulator, make sure that the pipeline connections are correctly made. The inlet and outlet valves should be closed.

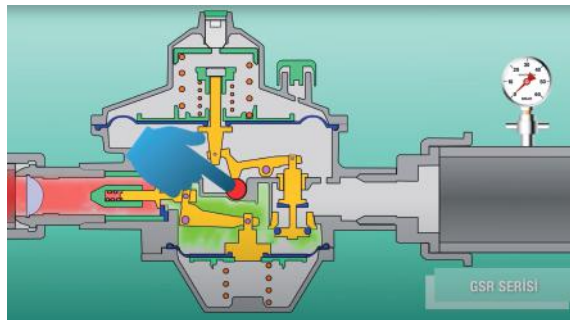

Slowly open the inlet valve, turn the knob on the regulator slowly to allow gas to enter, and release the knob. The regulator will automatically adjust itself once gas enters it.

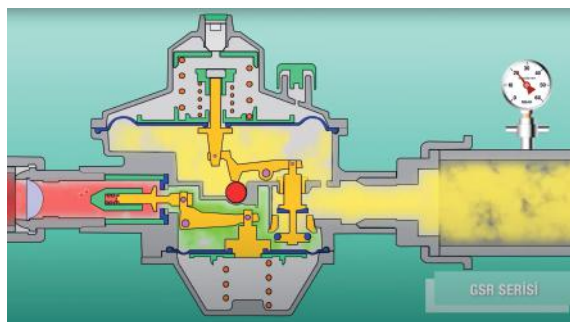

Slowly partially open the outlet valve and wait for the line to fill. Then, fully open the outlet valve. After commissioning, perform a leak test.

## SAFETY FEATURES

- Inlet Filter
- Excess Flow Safety
- Inlet Pressure Cut-off Safety
- Relief Safety Valve